

# ANTHONY CRANES

Mark: **SPIERINGS** Type: **SK488-AT4**

## Crane identification

Serial number:

Year of construction: \_\_\_\_\_

Crane group : 3 as per NEN 2018  
 Loadspectrum : 2 as per NEN 2018  
 Classification : A as per NEN 2018  
 Stability : as per NEN 2022

Identifacation-  
number

**93 tm**

Max. load

**8,0 tonne**

Max. radius  
with max. load

**12,76 m**

Max. capacity

**102 tm**

Max. jib lenght

**40m**

### Speeds

Jib horizontal / jib 30° luffed

	m/min	kg
	18	8000
	27	4000
	40	2000
	75	0
	0 - 70 m/min	
	0-0,9 rpm	

All motions with hydraulic proportinal controls

Luffing the jib 30° can be controlled from crane cab or via remote control

Driving with erected tower and jib, only with the jib horizontal and positioned over the front carriage, platform locked to the carrier and the outriggers fully extended (max. inclination 2°)

Rated lifting capacity is net capacity

Crane equipped with full counterweight: 8700 kg

360° continuous slewing, with outriggers out and down

Operation allowed up to a wind force :

Outrigger position : 7,95 x 7,66 m  
7 on the Beaufort scale (wind speed 17m/sec)

Outrigger position : 7,95 x 5,72 m  
6 on the Beaufort scale (wind speed 14m/sec)

Sail area of the load max. 1,0 m<sup>2</sup> / tonne at a windforce of 7 on the Beaufortscale.

Operating temperature range from -15° to 40° C.

In all cases 2 parts of line

Max. line pull force 4000 kg

The crane should be folded in at a windforce >9 (21m/sec) or when not in use for a longer period

### LIFTING CHART Outrigger spread 6,90 m x 6,84 m (up to wind force 7 on the beaufort scale)

#### Jib horizontal

Hookheight 25 m (height under jib 26,8 m)

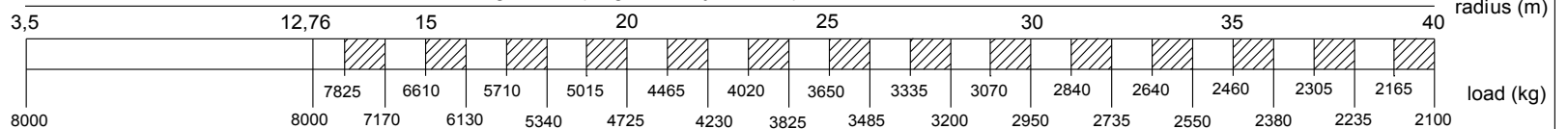

#### Jib 30° luffed

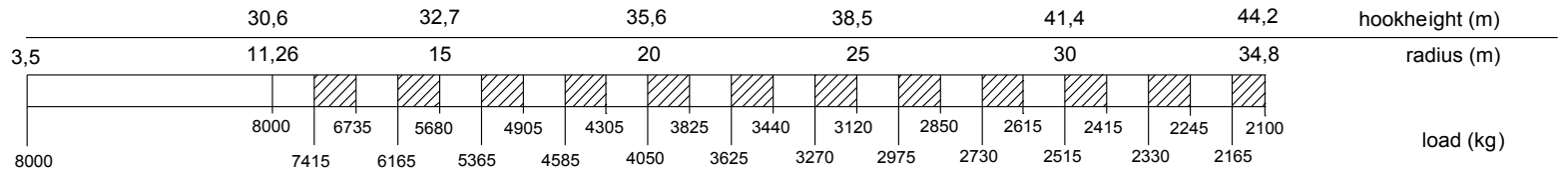

### LIFTING CHART Outrigger spread 6,90 m x 5,15 m (up to wind force 6 on the beaufort scale)

#### Jib horizontal

haakhoogte 25 m (hoogte onder de giek 26,8m)

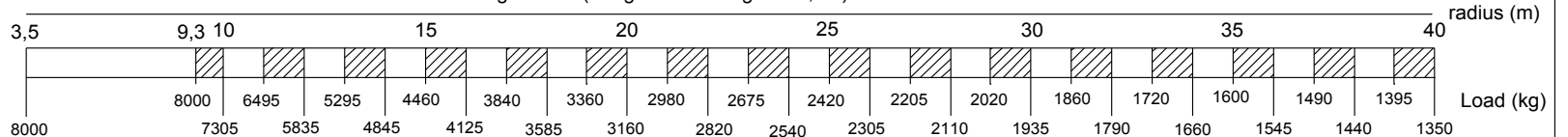

#### Jib 30° luffed

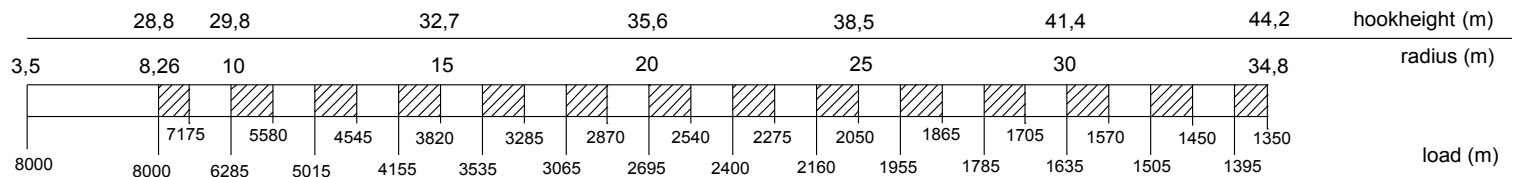

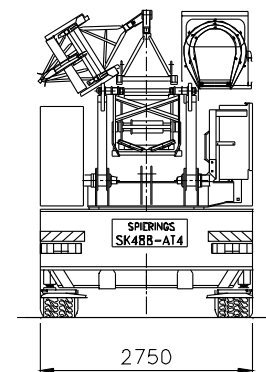
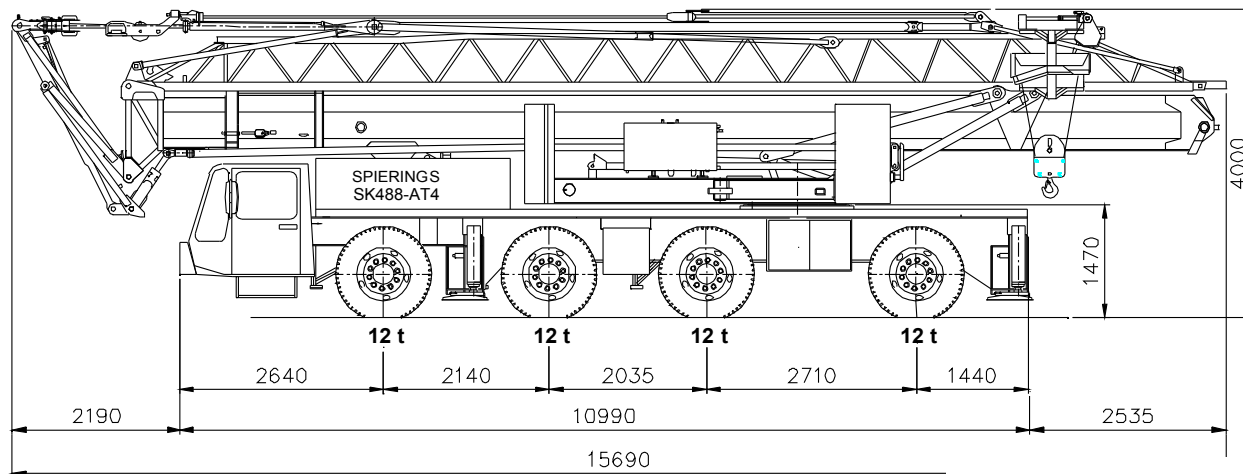
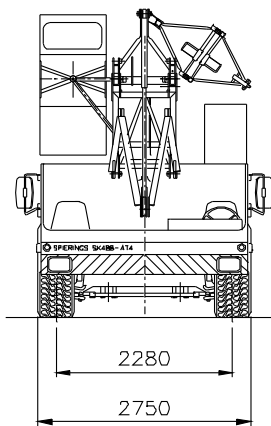
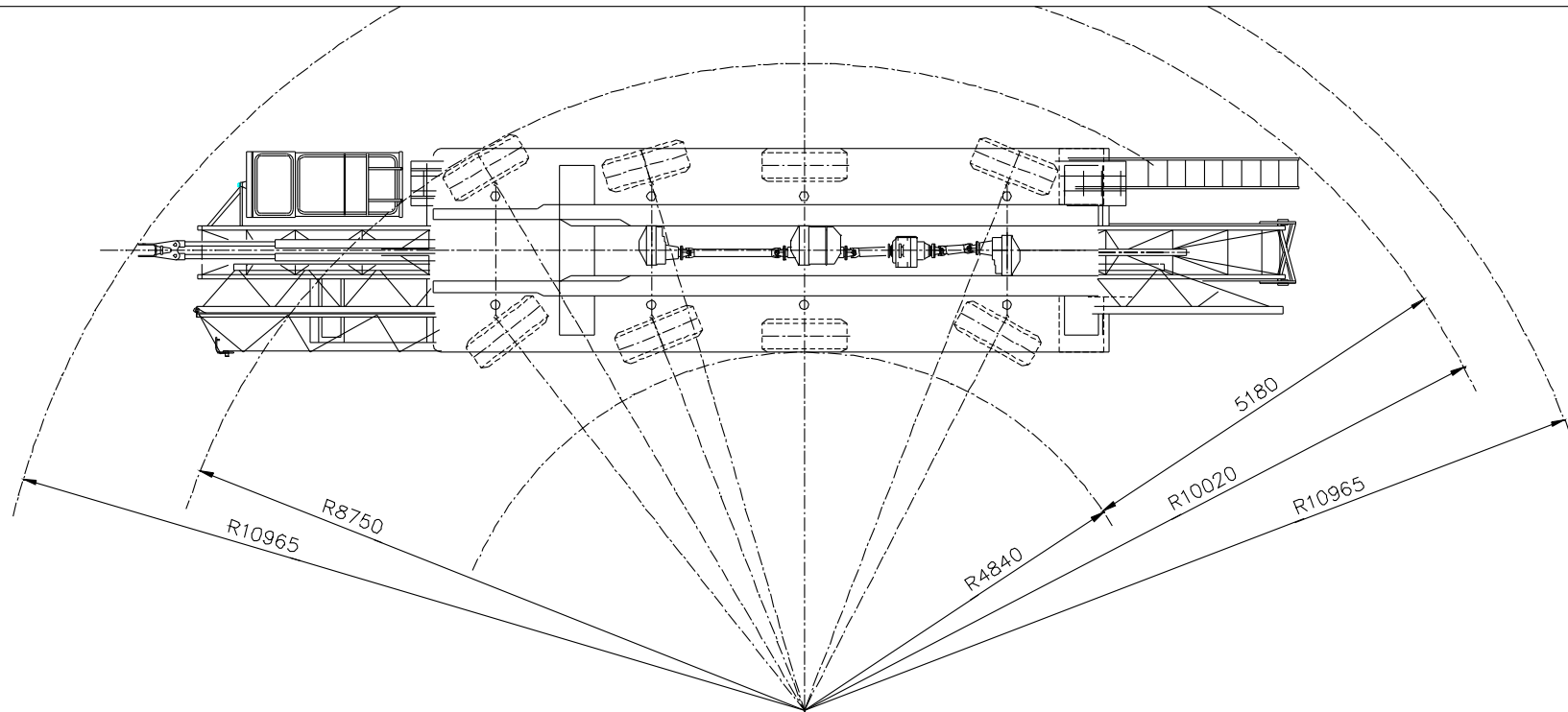

**SPIERINGS HYDRAULIC FOLDING  
SK 488 - AT4**

**ANTHONY  
CRANES**

Total weight: 4800 kg

Max. outrigger loading: 350 kN  
 Outrigger foot: 750x600 mm  
 Pressure under foot: 0.8 N/mm<sup>2</sup>  
 Jib can be unfolded trough 360°  
 Luffing the jib 30° can be controlled from de crane cab

**SPIERINGS**  
**HYDRAULIC FOLDING CRANE**  
**SK 488 - AT4**

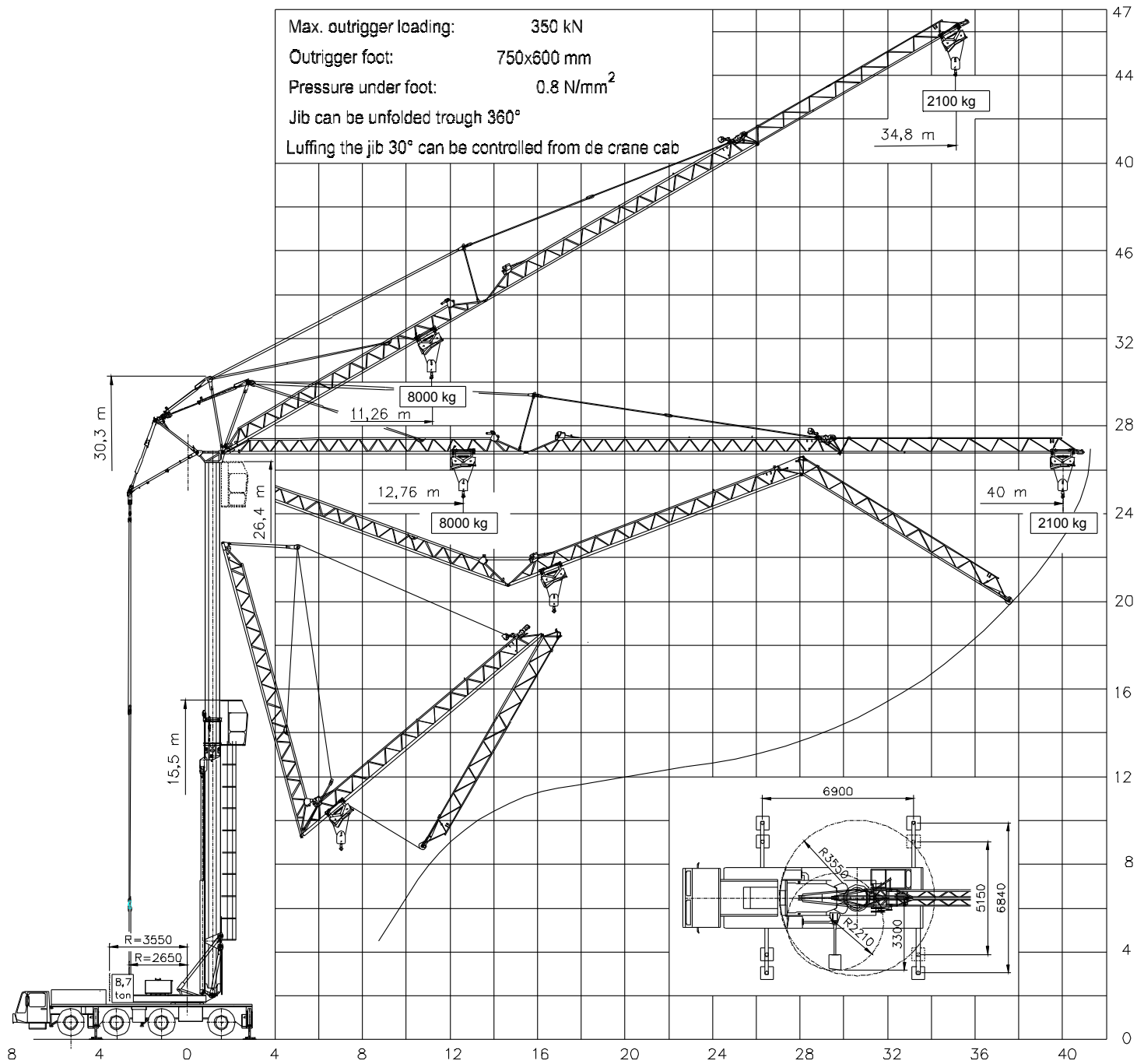

**ANTHONY**  
**CRANES**



# SPIERINGS HYDRAULIC FOLDING CRANE

## SK 488 - AT4

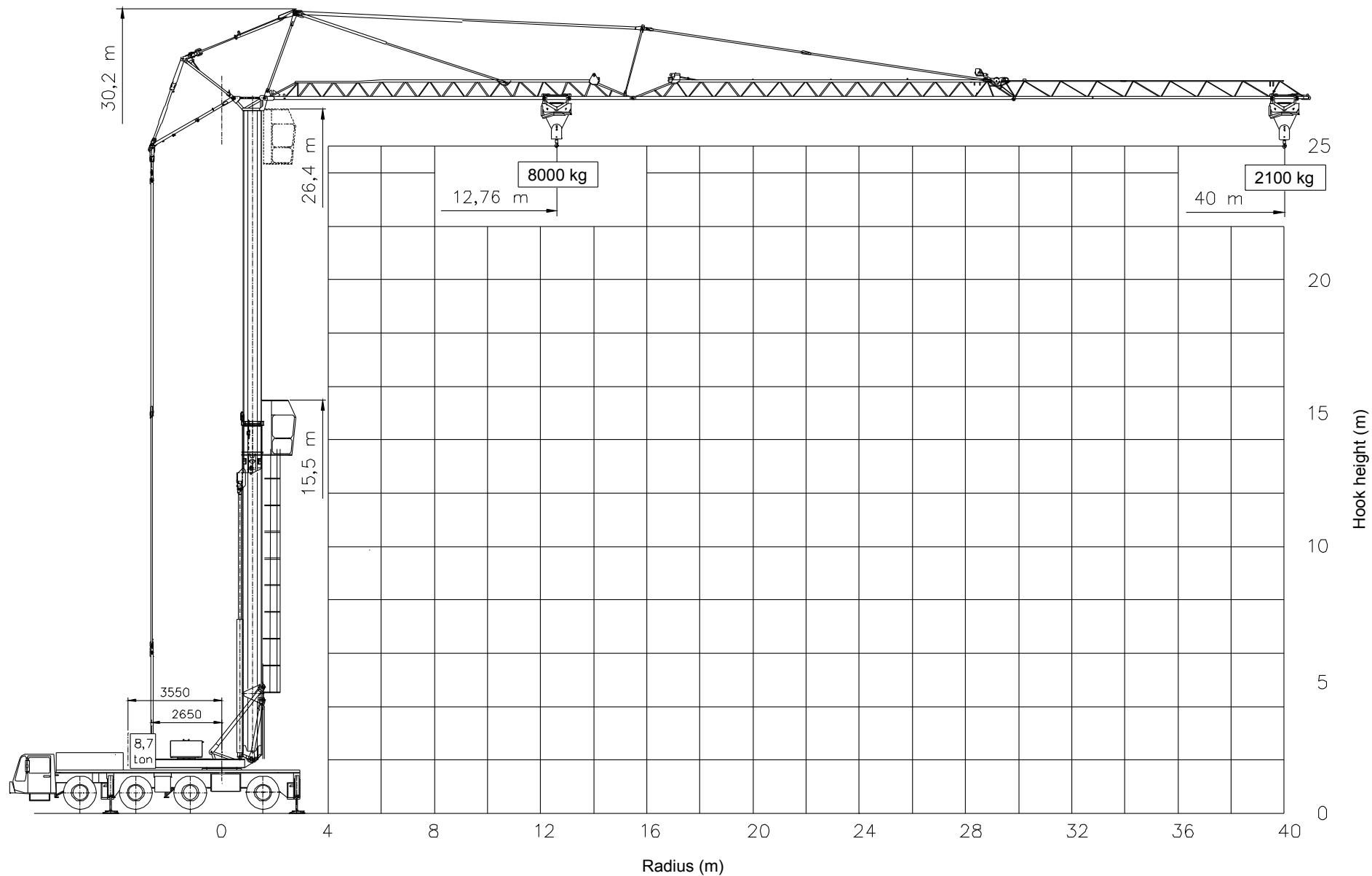

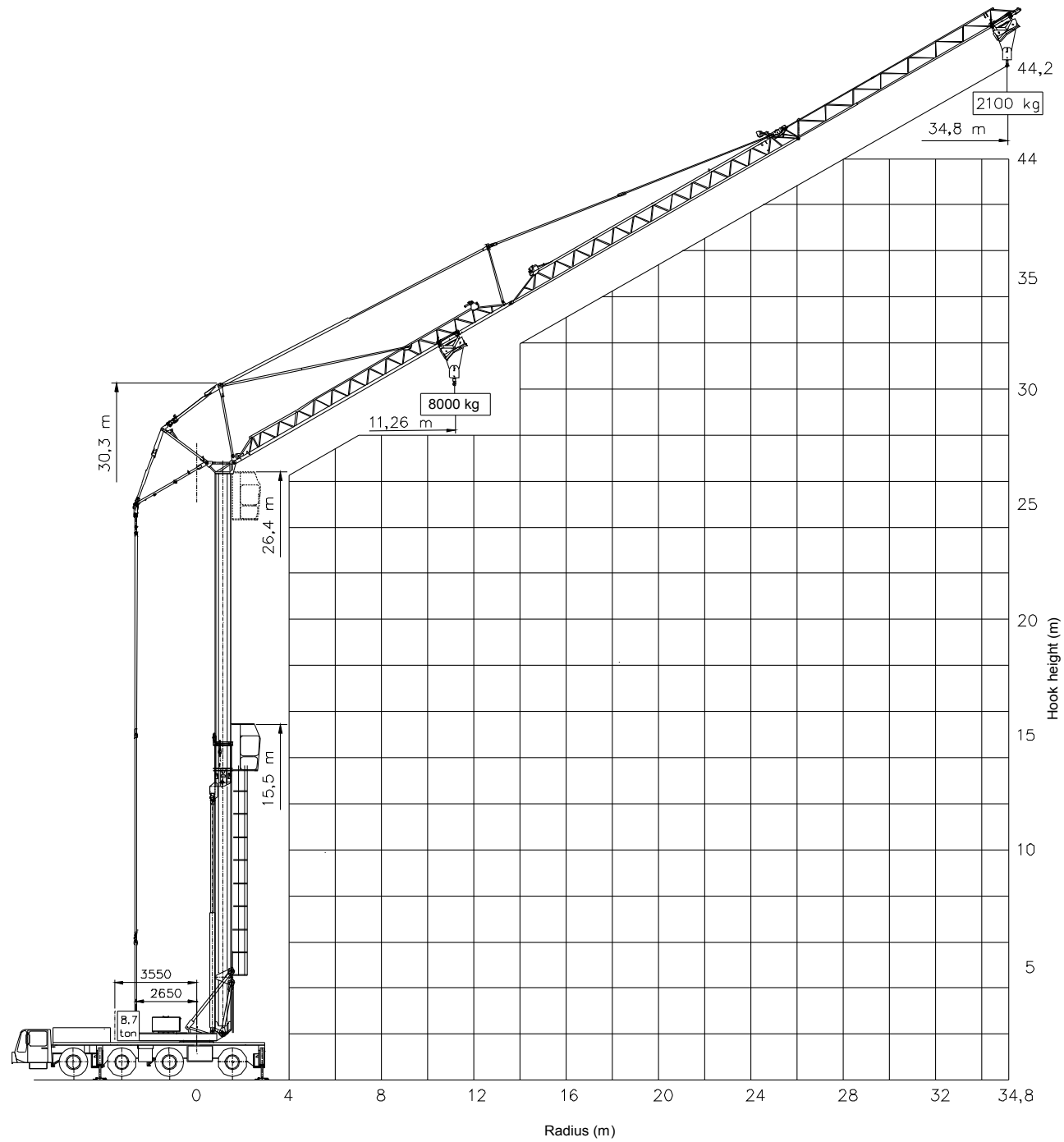

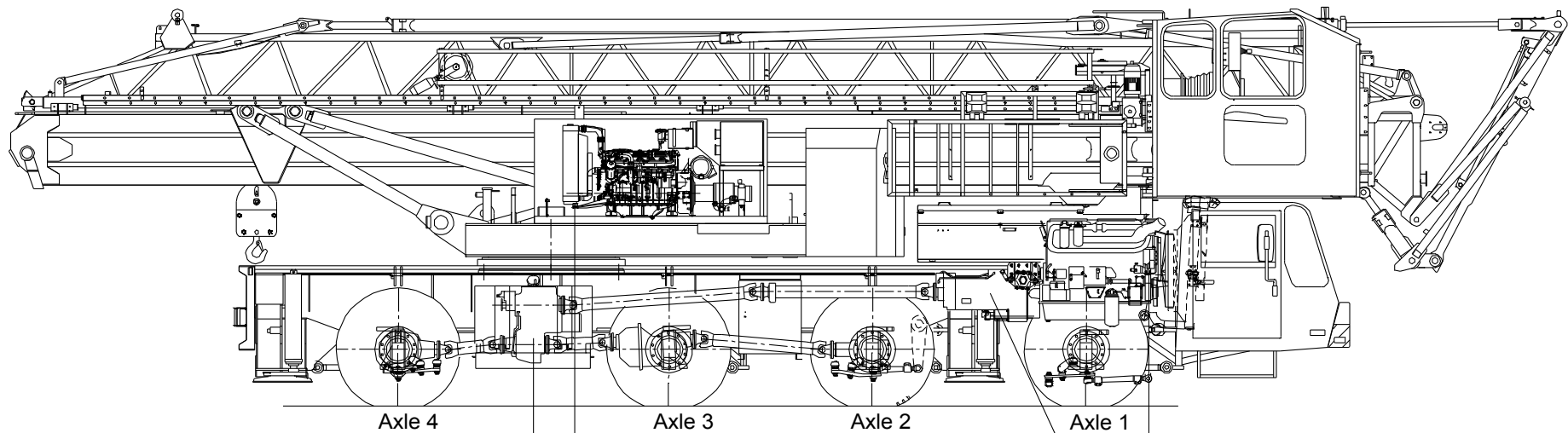

Transferbor:  
 STEYR VG2001/396  
 Road gear  $i = 0,89$   
 Off road gear  $i = 1,54$

Crane diesel engine  
 DETROIT VM D706 IE2  
 Power: 96 kW (2600 rpm)  
 Torque: 480 Nm (1300 rpm)

Gearbox:  
 ZF 16S151  
 Manually operated  
 + air power assistance  
 + dry plate clutch

Carrier diesel engine:  
 DAF XE 280 C (EURO 3)  
 Power: 280 kW (1900 rpm)  
 Torque: 1750 Nm (1500 rpm)

Axle 1 : Steer axle	Tyres	: 445/75 R22,5
Axle 2 : Steer drive axle (end reduction $i=6,57$ )	Suspension: hydro-pneumatic on all axles; stroke cyl.	: 247 mm
Axle 3 : Drive axle, not steering (end reduction $i=6,57$ )	Max. speed carrier	: 85 km/h
Axle 4 : Steer drive axle (end reduction $i=6,57$ )	Min. speed carrier (engine at 1000 rpm)	: 1,6 km/h
	Overall weight	: 48.000 kg.

## Drive train Spierings Folding Crane SK488-AT4